

Technical Datasheet



HM F Series

Turbine Flow Meters
with Flange Connections

Description

The HM F turbine flow meter series (F for flange connections) is used to measure continuous and discontinuous flow rates. They are mainly used for lubrication and non-lubrication media. They are particularly suitable for low and medium viscosity liquids, such as water, emulsions, glycol mixtures and light oils.

Only high-grade steels that can withstand corrosive liquids are used in the production of turbine flow meters. Combined with the use of tungsten carbide bearings, the HM F guarantees optimum measurement accuracy and an extremely long service life even under the toughest application conditions.

The combination of various turbine wheel dimensions and blade geometries allows a wide range of sizes that can cover a huge measuring range. This makes the HM F ideal for a variety of applications in the field of metering as well as for monitoring, mixing and dosing.

Short response times, very dynamic performance and high measurement accuracy ensure accurate regulation and control of flow rates in the most demanding applications.

For applications in hazardous areas, we offer intrinsically safe sensors and amplifiers with Ex protection in accordance with ATEX, IECEx, CSA and other standards. Additional certifications such as EAC (TR-CU) are available.

Principle and Design

Turbine flow meters (HM) are volume counters operating on the Woltmann impeller counter principle. They use the average flow velocity to record the flow rate through the pipe

The flow of the medium is directed at the turbine wheel in the axial direction and so rotated. The speed of the freely turning wheel over a wide range is directly proportional to the average flow velocity. The low weight of the turbine wheel ensures very short response times as well as very dynamic behaviour in flow changes. Two flow straighteners generate quasi-laminar flow, which in turn contributes to increasing the measurement accuracy.

The speed of the turbine wheel is measured by the sensor through the housing wall. The sensor system can be selected to meet the requirements of the individual application. This can provide, for example, a signal to indicate the direction of flow.

Pulses per unit of volume are available for analysis. The calibration factor (K-factor) of the flow meter describes the exact pulse rate per unit of volume. In order to determine the individual calibration factor of a flow meter, we calibrate each of our meters in house prior to delivery. The operating viscosity specified by the customer is taken into account for calibration. A corresponding calibration certificate is included with every flow meter we supply.

The KEM turbines feature a short response time between 5 and 50 ms depending on the nominal diameter, which is advantageous for precise filling processes.

Turbine flow meters have a resolution of up to 3,000 pulses per litre. The milled and turned precision components are the reason why the HM series has neither wetted weld seams nor soldered connections. All market-related requirements for piping and material standards can thus be fully guaranteed.

Applications

- Consumption measurement
- Filling process
- Dosing systems
- 2-component mixing plants
- Test stands
- Water (polluted and demineralized)
- Hydraulic and gear oils
- Fuels, gasoline, kerosene
- Coolants
- Additives
- Solvents
- Pharmaceutical liquids

Features

- Exceptional repeatability of $\pm 0.05\%$
- Short response times (from 5 ms)
- Robust carbide bearing
- Medium temperature: $-60\text{ }^{\circ}\text{C}$ up to $+350\text{ }^{\circ}\text{C}$ [$-76\text{ }^{\circ}\text{F}$ up to $+662\text{ }^{\circ}\text{F}$]
- Different nominal sizes
- Flange standard DIN Form B, ASME Raised Face (RF)

Technical Data – Sizes

Connection Size	Measuring Range (l/min)				~ K-Factor (pulses/l)	~ max. Fre- quency (Hz)
	Standard		Extended			
	Min	Max	Min	Max		
DN 15 - 1/2"	5	50	1	50	3,150	2,625
DN 25 - 1"	20	250	3	250	445	1,854
DN 40 - 1 1/2"	50	750	10	750	106	1,325
DN 50 - 2"	70	1,200	20	1,200	65	1,300
DN 65 - 2 1/2"	100	2,000	30	2,000	25	833
DN 80 - 3"	160	3,200	45	3,200	11	587
DN 100 - 4"	250	5,000	—	—	7	583
DN 150 - 6"	350	10,000	—	—	2.5	417

Measuring Accuracy Standard: $\pm 1\%$ of flow rate

Measuring Accuracy Premium¹⁾: $\pm 0.5\%$ of flow rate

Repeatability: $\pm 0.05\%$ (in standard measuring range)

All data is valid under reference conditions²⁾

Technical Data – General

Viscosity Range (Standard)	1 up to 10 mm ² /s
Pressure Rating	16 up to 250 bar [232 up to 3,626 psi] (at room temperature) defined by the specification of the flange connections
Temperature Rating (Medium)	-60 °C up to +350 °C [-76 °F up to +662 °F]
Materials	Housing: as per DIN 1.4404 [AISI 316L], other material on request Internal parts: as per DIN 1.4404 [AISI 316L], other material on request Wheels: as per DIN 1.4462 [AISI 318 LN], other material on request Bearing: Tungsten carbide sleeve bearing



¹⁾ Only in combination with suitable electronics with linearization function.

²⁾ Reference conditions: viscosity 1 mm²/s; ambient temperature 23 °C [73 °F] ± 5 °C [9 °F]; ambient pressure 963 mbar [14 psi] ± 50 mbar [0.7 psi]; Humidity 60 % ± 30 %.

Turbine Flow Meters – HM F Series

Dimensional Drawing

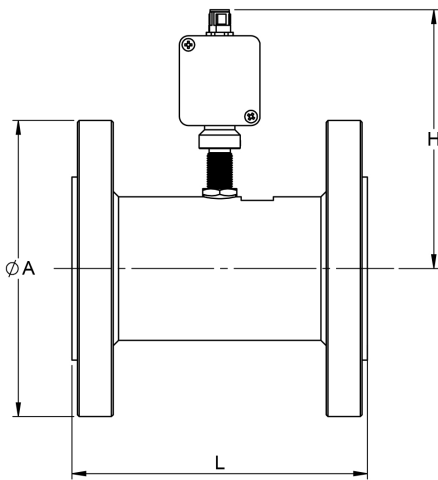

Metric flanges as per DIN-EN 1092-1 Form B

Connection size	L	ØA - Flange diameter					H ³⁾
		PN 16	PN 40	PN 100	PN 160	PN 250	
DN 15	127 mm [5.00 in]	Please use PN 40.	95 mm [3.74 in]	105 mm [4.13 in]	105 mm [4.13 in]	130 mm [5.12 in]	125 mm [4.92 in]
DN 25	140 mm [5.50 in]		115 mm [4.53 in]	140 mm [5.51 in]	140 mm [5.51 in]	150 mm [5.91 in]	132 mm [5.20 in]
DN 40	152 mm [6.00 in]		150 mm [5.91 in]	170 mm [6.69 in]	170 mm [6.69 in]	185 mm [7.28 in]	140 mm [5.51 in]
DN 50	165 mm [6.50 in]	165 mm [6.50 in]	165 mm [6.50 in]	195 mm [7.68 in]	195 mm [7.68 in]	200 mm [7.87 in]	145 mm [5.71 in]
DN 65	178 mm [7.00 in]	185 mm [7.28 in]	185 mm [7.28 in]	220 mm [8.66 in]	220 mm [8.66 in]	—	153 mm [6.02 in]
DN 80	254 mm [10.00 in]	200 mm [7.87 in]	200 mm [7.87 in]	230 mm [9.06 in]	230 mm [9.06 in]	—	160 mm [6.30 in]
DN 100	305 mm [12.00 in]	220 mm [8.66 in]	235 mm [9.25 in]	265 mm [10.43 in]	—	—	170 mm [6.69 in]
DN 150	356 mm [14.00 in]	285 mm [11.22 in]	300 mm [11.81 in]	355 mm [13.98 in]	—	—	195 mm [7.68 in]

Inch flanges as per ASME B 16.5, Raised Face (RF)

Connection size	L	ØA - Flange diameter					H ³⁾
		Class 150	Class 300	Class 600	Class 900	Class 1500	
½ inch	127 mm [5.00 in]	90 mm [3.54 in]	95 mm [3.74 in]	95 mm [3.74 in]	Please use class 1500.	120 mm [4.72 in]	125 mm [4.92 in]
1 inch	140 mm [5.50 in]	110 mm [4.33 in]	125 mm [4.92 in]	125 mm [4.92 in]		150 mm [5.91 in]	132 mm [5.20 in]
1½ inch	152 mm [6.00 in]	125 mm [4.92 in]	155 mm [6.10 in]	155 mm [6.10 in]		180 mm [7.09 in]	140 mm [5.51 in]
2 inch	165 mm [6.50 in]	150 mm [5.91 in]	165 mm [6.50 in]	165 mm [6.50 in]		215 mm [8.46 in]	145 mm [5.71 in]
2½ inch	178 mm [7.00 in]	180 mm [7.09 in]	190 mm [7.48 in]	190 mm [7.48 in]		245 mm [9.65 in]	153 mm [6.02 in]
3 inch	254 mm [10.00 in]	190 mm [7.48 in]	210 mm [8.27 in]	210 mm [8.27 in]	240 mm [9.45 in]	—	160 mm [6.30 in]
4 inch	305 mm [12.00 in]	230 mm [9.06 in]	255 mm [10.04 in]	275 mm [10.83 in]	290 mm [11.42 in]	—	170 mm [6.69 in]
6 inch	356 mm [14.00 in]	280 mm [11.02 in]	320 mm [12.60 in]	355 mm [13.98 in]	—	—	195 mm [7.68 in]

³⁾ The specified values result from the dimensions of the respective turbine plus ECO X-K-X pulse amplifier.

Ordering Code

HM - XXX - XXX - XXX - XX - XX

Connection size

DN 15	015
DN 25	025
DN 40	040
DN 50	050
DN 65	065
DN 80	080
DN 100	100
DN 150	150
½ inch	½"
1 inch	1"
1 ½ inch	1 ½"
2 inch	2"
2 ½ inch	2 ½"
3 inch	3"
4 inch	4"
6 inch	6"

Flange norm & form

DIN EN 1092-1 Form B	FDB
ASME B16.5 Raised Face	FAB

Pressure rating

PN 16	16
PN 40	40
PN 100	100
PN 160	160
PN 250	250
Class 150	150
Class 300	300
Class 600	600
Class 900	900
Class 1500	1500

Material housing and internal parts

DIN 1.4404 [AISI 316L]	04
------------------------	----

Pickup holes

Single pickup M14x1.5	G
Single pickup M14x1.5; Exd-capable (not possible for DN 15 / ½")	Z
Single pickup 3/8" NPT Exd-capable	B

Other variants on request

Turbine Flow Meters – HM F Series

Calibration

In-house calibration is performed on volumetric calibration rigs or in our accredited calibration laboratory, depending on the needs of the client.

The calibrations are performed with different hydrocarbons. This ensures the optimum simulation of changing operating conditions in density and viscosity even when temperatures change. This way the primary viscosity for the use of the flow meter can be specifically taken into account when viscosity fluctuations occur in a customised application.

The calibration result is the specified calibration factor (K-factor) in pulses per litre. This K-factor accordingly applies only at a certain flow velocity or a certain flow rate. The calibration factor varies only very slightly at different volume flow rates. The individual measuring points provide the calibration curve of the flow meter from which the average K-factor is determined. The average calibration factor applies to the entire measuring range.

The linearity specification (percent deviation) refers to the average K-factor. To further increase the measurement accuracy in onsite use, the specific K-factors can be used to calculate the flow rate. For this, KEM also supplies optional special electronics.

For special requirements on the traceability of the results, it is possible to perform an accredited calibration on customer request. The KEM accredited calibration lab uses a high-precision load cell system. With an accuracy of 0.05 % for the mass and 0.1 % for the volume of flowing liquids, we occupy a leading position worldwide. The laboratory is accredited with engineers, processes and measuring equipment according to the international standard DIN EN ISO/IEC 17025:2018.

The KEM accredited calibration certificate not only verifies the accuracy of a flow meter, but also guarantees its traceability to national standards ensuring all requirements according to international quality standards are met.

Calculation of volume flow

The flow is directly dependent on the measured frequency and the associated calibration factor:

$$Q = \frac{f \cdot 60}{K} \text{ l/min}$$

- Q = Volume Flow
- f = Measuring frequency
- K = K-Factor

Typical calibration curve Turbine Flow Meter (@ 1 mm²/s)

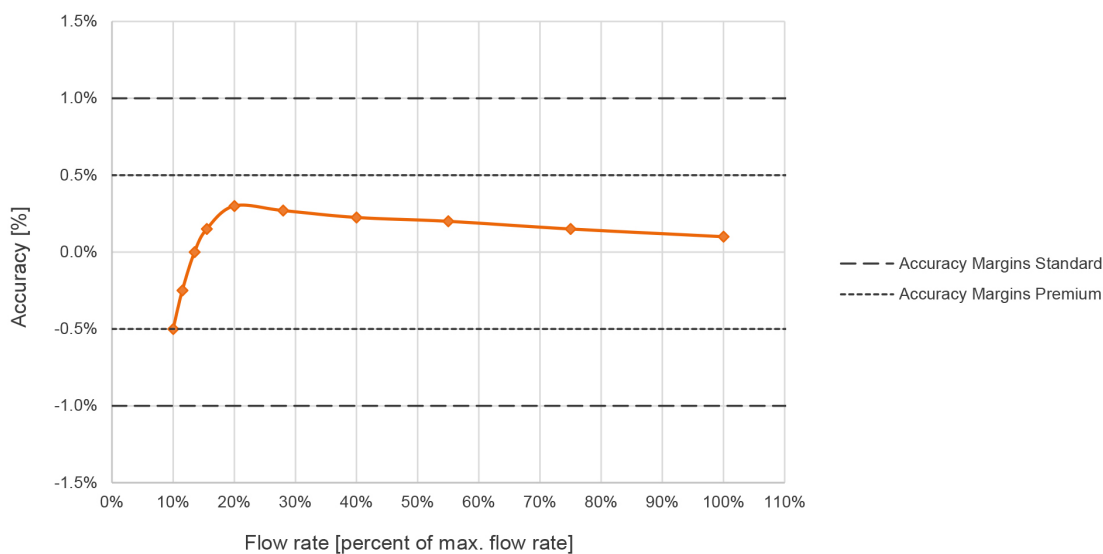



KEM Flow Measurement GmbH



+49 9941 9423-0



Wetzeller Straße 22
93444 Bad Kötzing
Germany



info@kemflow.com



www.kemflow.com