

Technical Datasheet



EWS

Intrinsically Safe Supply Unit

Description

The EWS supplies KEM pickups installed in hazardous areas and transmits the output frequency of these pickups. The input and output circuits of the EWS are galvanically isolated. The EWS must be installed outside hazardous areas.

An intrinsically safe supply circuit 12 V to supply intrinsically safe KEM pickups installed in hazardous areas in threewire technique.

Two intrinsically safe signal input circuits ATEX II (2)G [EEx ia] IIC to connect pickups as per DIN 19234 (NAMUR) in two-wire technique and for the connection of active and passive pickups. LEDs will indicate short circuit and line breakage.

Features

- Frequency doubling and detection of rational direction
- Failure signalling relay for NAMUR mode

Output

- Open-Collector
- PLC output active 24 V
- NAMUR DIN 19234

Technical Data

Input circuits (intrinsically safe) terminals KL1, KL2, KL3, KL4

Supply circuits terminals KL1, KL3

Galvanic isolation to the outputs and the power supply.

Open Circuit Voltage	12 V ±5 %
Series Resistor	120 Ω
Max. Operating Current	20 mA
Short Circuit Current	$I_{max} = 110 \text{ mA}$ (short circuit proof)
Parameters for Safety Regulations	$U_{max} = 12.6 \text{ V}$ $I_{max} = 110 \text{ mA}$ $P_{max} = 342 \text{ mW}$ $L_i \approx 0; C_i \approx 0$

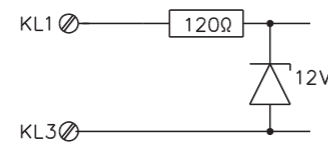

Signal Input KL2, KL3, KL4

- Intrinsically safe signal input circuits according to DIN 19234 NAMUR for connection of active and passive pickups
- Galvanic isolation to the outputs and power supply
- Isolation of outputs and mains supply (no isolation of signal inputs and the intrinsically safe supply circuit)
- Separate indication of short circuit and line breakage for each channel by a red LED

Open Circuit Voltage	8.5 V
Short Circuit Current	15 mA (short-circuit proof)
Max Power	30 mW
Switch Rate f_{max}	5 kHz for outputs as per DIN 19234
Duty Cycle	1:1
Switch Time	200 μs (under test conditions)
Switch Current Difference	0.25 mA ± 0.15 mA
Switch Level	ON - transistor conducting ≤ 1.65 ±0.15 mA OFF - transistor blocked ≥ 1.85 ±0.2 mA
Switch State for Line Breakage (LB)	$I < 150 \text{ μA}$ transistor conducting
Switch State for Short Circuit (KS)	$R_L < 360 \text{ Ω}$ transistor blocked
Safety-Relevant Parameters	$U_{max} = 12.6 \text{ V}$ $I_{max} = 18 \text{ mA}$ $P_{max} = 55 \text{ mW}$ $L_i \approx 0; C_i \approx 0$

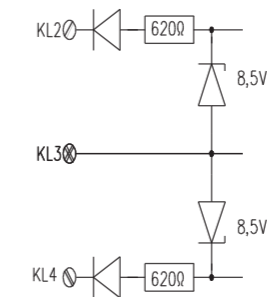

Outputs (not intrinsically safe) Terminals KL6, KL7, KL8

The intrinsically safe input circuits are isolated from the mains supply and the outputs which are not intrinsically safe.

Open Collector NPN

0 V for both outputs common.

I_{max}	100 mA
U_{max}	30 V
UCE_{min}	1 V
UCE_{max}	1.5 V
Switch Rate f_{max}	2.5 bis 5 kHz According to external wiring and duty cycle
Max. Transmission f_{max} (typical figures)	U < 5 V; R < 2 kΩ; f_{max} < 5 kHz U < 12 V; R < 1 kΩ; f_{max} < 5 kHz U < 12 V; R < 2 kΩ; f_{max} < 4.5 kHz U < 24 V; R < 5 kΩ; f_{max} < 3 kHz Duty cycle 1:1; R = pullup; U = applied voltage

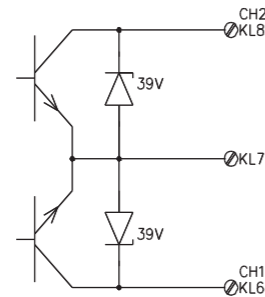

DIN 19234 (NAMUR)

0 V for both outputs common.

Low Level	< 1 mA
High Level	> 2.2 mA
U_{max}	30 V
I_{max}	25 mA
P_{max}	0.4 W
Switch Rate f_{max}	5 kHz (duty cycle 1:1)

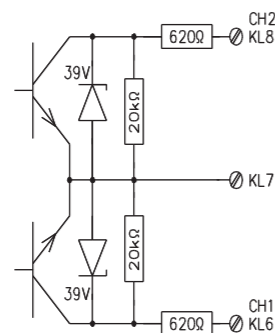

Active 24 V/PLC Version

0 V for both outputs common.

High Level	> 22 V - (620 Ω × I_{out}) max. 30 V
Low Level	Blocking
I_{max}	10 mA/channel
Short Circuit Resistance	Max 2 h
Switch Rate f_{max}	2 up to 3.5 kHz According to external wiring and duty cycle

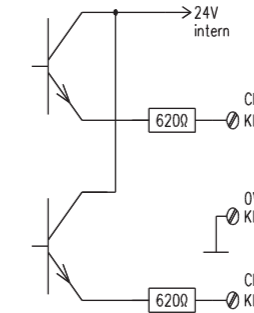

Supply Terminals KL9, KL10

Supply Voltage and Power Consumption

24 V DC	20 - 35 V	approx. 3 VA at 24 V DC approx. 5 VA with the SP option
---------	-----------	--

Further Technical Data

Ambient Temperature	0 °C up to +50 °C [+32 °F up to +122 °F]
Ingress Protection Housing	IP20
Housing	Plastics
Dimensions	l = 70 mm, w = 45 mm, h = 115 mm and 125 mm with option SR
Installation	Mounting rail DIN EN 50022-35 or wall mounting
Terminals	Electric shock hazard protection as per VDE 0106/100
Wire Size	Max 2 × 2.5 mm ²
Weight	350 up to 450 g

Options

Frequency Doubling and Detection of Rotational Direction

The EWS doubles the frequency of two frequency signals which are phase-shifted by 90° (± 30°). The duty cycle of the doubled frequency is variable. The EWS detects the rotational direction by the phase.

Outputs (non-intrinsically safe)

Forward/Backwards Detection	channel 1 (terminals KL6, KL7) transistor conducting (channel 2 leads) transistor blocked (channel 2 lags)
Doubled Frequency	channel 2 (KL8, KL7)

The following applies:

- The output transistor of channel 1 (terminals KL6, KL7) conducts, if the input signal 2 (KL 4) leads.
- For type TD pickups in gear flow meters connected as shown on page 6: The output transistor of channel 1 conducts, if the arrow direction on the type plate of the gear flow meter and the flow direction are the same.

Failure Signalling Relay for NAMUR Mode

potential free relay contact: $U_{max} = 30\text{ V}$, $I_{max} = 100\text{ mA}$, $R_i = 12\ \Omega$

The relay will drop out with:

- Drop in operating voltage
- Short circuit or line breakage of one or both intrinsically safe signal input circuits terminals KL4, KL3 or KL2.

Safety Instructions

- Please consider the following:
 - Installation specifications for associated devices which are intrinsically safe
 - The »Safety regulations for electrical devices«
 - The »Special conditions for safe use« as per EC-Type Examination Certificate
- The EWS must be installed outside hazardous areas.
- The max length for cables to connect pickups or amplifiers is 500 metres.
- Max ambient temperature must not exceed +50 °C [+122 °F] (please also consider self heating). A gap of at least 30 millimetres should be kept between two EWS units.
- The inputs are suitable for both active and passive pickups.
- When the max switch frequency is bypassed, no output signal will be available. Therefore a bypassing of the max. switch frequency has to be avoided with safety-relevant measurements. The max. switch frequency depends on the duty cycle of the input signals and the wiring of the outputs (cf. technical data »outputs«).
- For detection of the rotational direction, the frequency signals of the pickup must be of the same frequency and be phase-shifted by 90° (± 30°). If this is not the case, you will receive undefined output signals.

Connections

Terminal Connections:

Intrinsically safe current circuits

- 1 = $U_B +12\text{ V}$
intrinsically safe supply
- 2 = input channel 1
- 3 = 0 V pickup supply and
signal input circuits
- 4 = input channel 2
- 5 = n.c.

not intrinsically safe current circuits

- 6 = output channel 1 (flow direction)
- 7 = 0 V of signal outputs
- 8 = output channel 2 (2x f)
- 9 = $-U_B$
- 10 = $+U_B$
- 14 = failure-signalling relay
- 15 = failure-signalling relay

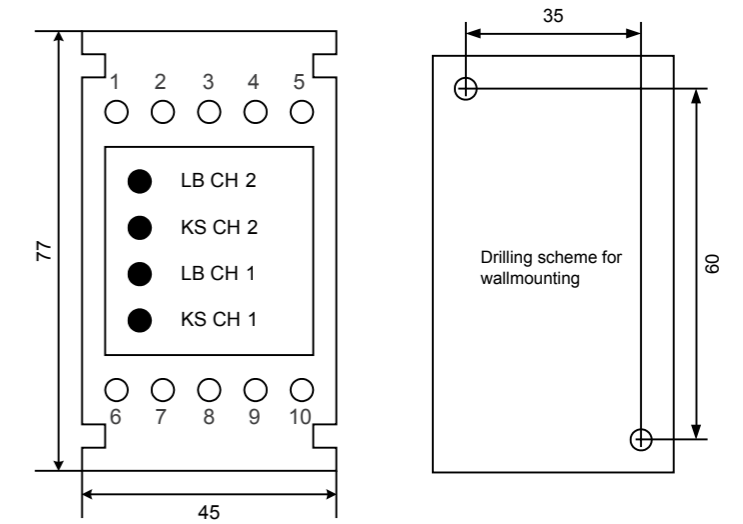

Wiring Example

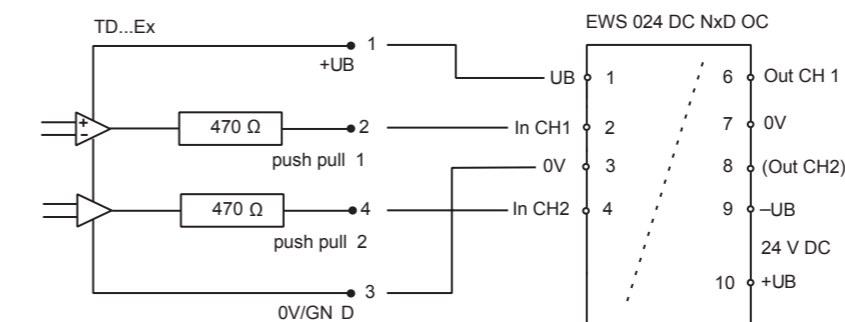
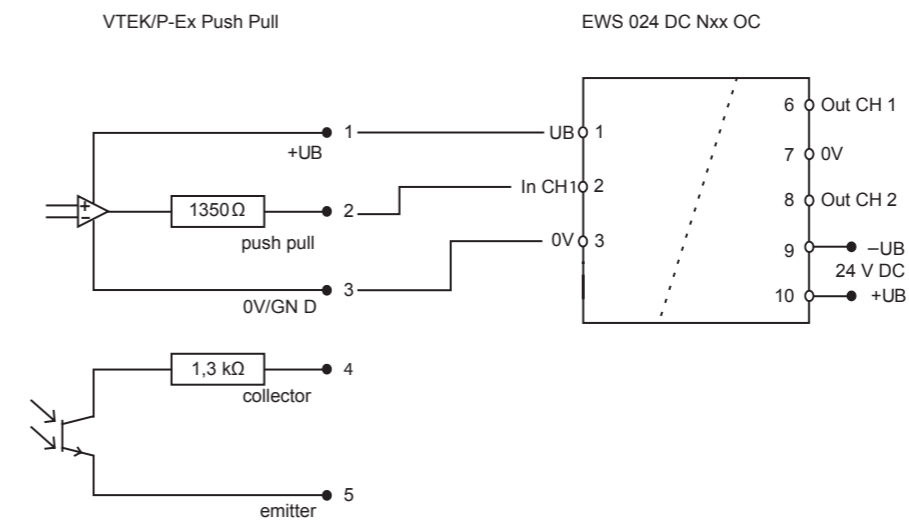

Wiring Diagram

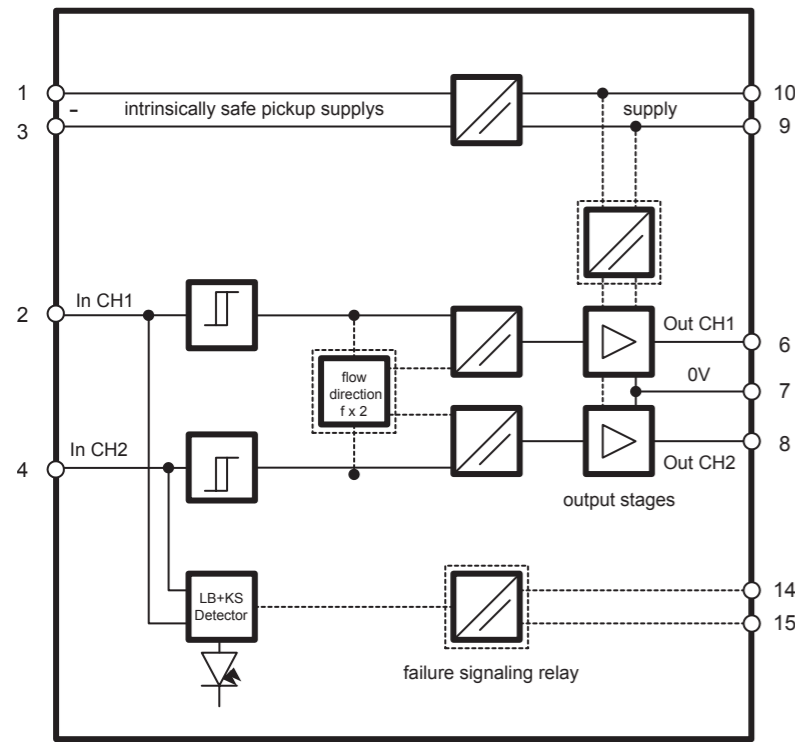

Marking

KEM Küppers Elektromechanik GmbH
 Ⓔ 0123 Ⓔ II (2)G [EEx ia] IIC
 BVS 03 ATEX E 208
 EWS xxxxx-Nxx-xx Nr. 1234567
 0° C ≤ Ta ≤ 50 °C

KL1/3
 U_{max} = 12.6 V; I_{max} = 110 mA; P_{max} = 342 mW
 C_i = 0; L_i = 0

KL2/3 and KL3/4
 U_{max} = 12.6 V; I_{max} = 18 mA; P_{max} = 55 mW
 C_i = 0; L_i = 0

Special Conditions for Safe Operation

The EWS described above is an »affiliated intrinsically safe device«. It must not be installed in hazardous areas. The device shall only be connected with intrinsically safe devices of a certified type or such corresponding to paragraph 1, EN 50020:1994. This connection must be in a way that the intrinsic safety is maintained.

For a safety factor of 1.5 the electrical parameters of connection (leads and intrinsically safe device) must not exceed the following (maximum) values:

pickup supply: terminal KL1 and KL3: C = 1 µF; L = 3 mH
 signal inputs: terminal KL2 - KL3 and terminal KL4 - KL3: C = 1 µF; L = 100 mH

Ordering Code

EWS X - N X X - X - X

Supply Voltage

024 DC = 24 V DC

Inputs

Standard, cf. »input circuits«, page 2

Reverse-flow detection and doubled frequency

N	x	x
N	x	D

Outputs

Open collector (standard)

NAMUR (DIN 19234)

Aktive 24 V (SPS-Output)

OC
 NA
 SP

Failure-signalling relay (only for NAMUR input signals)

SR



KEM Flow Measurement GmbH



+49 9941 9423-0



Wetzeller Straße 22
93444 Bad Kötzing
Germany



info@kemflow.com



www.kemflow.com