

Technical Datasheet



ZHA KL Series

Gear Flow Meters Aluminum Version
with ball bearing for lubricating media

Gear Flow Meters – ZHA KL Series

Overview

With more than 50 years of experience in the flow measurement field and numerous innovative and customer-specific product developments, we are a qualified and competent contact for flow measuring technology and calibration. KEM offers a broad selection of measuring principles for this purpose. We develop, produce, and deliver high quality Gear Flow Meters, Turbine Flow Meters, Helical Flow Meters and Micro Flow Meters as well as Coriolis Mass Flow Meters worldwide. Specific accessories complement the product range.

This document provides information, technical details and typical applications concerning the ZHA KL Gear Flow Meter Series.

Series	Application	Process Medium	Attributes
ZHM ST	Flow measurement	Polyol + isocyanat, glue, epoxy resins Abrasive, less lubricating Medium/high viscosity	Stainless steel body Tungsten carbide sleeve bearing Bigger tolerances
ZHM KL	Filling processes	Lubricants, oils, grease Lubricating Medium/high viscosity	Stainless steel body Stainless steel ball bearing Bigger tolerances
ZHM MK	Dosing & consumption	Diesel, Skydrol, AdBlue, odorant (Less) lubricating Low viscosity	Stainless steel body Stainless steel ball bearing Small tolerances
ZHA KL	Test bed monitoring (Hydraulics)	Hydraulic fluid, ATF Lubricating Medium viscosity	Aluminum body Stainless steel ball bearing Bigger tolerances
ZHM CT	Dosage control (Paint shops)	Paints, waxes, amine Less lubricating Medium viscosity	Stainless steel body Tungsten carbide sleeve bearing Ball bearing (optional)
ZHM HP	Flow measurement (High Pressure)	Lubricants, coolant, inhibitors Abrasive, less lubricating Medium/high viscosity	Stainless steel body Stainless steel ball bearing Tungsten carbide sleeve bearing (optional)

Please contact KEM Sales for additional information on our Flow Meters or for advisory purposes related to your individual application needs. For KEM Sales contact details see the document's last page.



Description

The ZHA KL gear flow meter series (aluminum design) are flow meters which are mainly used in lubrication and non-lubrication liquids. They are equally suitable for filled, viscous and abrasive media.

Only high-strength aluminum is used in manufacturing the gear flow meters. Combined with the use of high quality precision ball bearings, the ZHA KL guarantees optimum measurement accuracy and a long service life even under the toughest application conditions. The ball bearings facilitate a very low starting torque of the measuring element. This way even the lowest flow rates at low viscosities can be accurately measured.

The combination of various gear dimensions and modules allows a wide range of sizes that can cover a huge measuring range. This makes the ZHA KL ideal for a variety of applications in the field of metering as well as for monitoring, mixing and dosing.

Short response times, very dynamic performance and high measurement accuracy ensure accurate regulation and control of flow rates in demanding applications.

For applications in hazardous areas, we offer intrinsically safe sensors and amplifiers with Ex protection in accordance with ATEX, IECEx, CSA and other standards. Additional certifications such as EAC (TR-CU) are available.

Principle and Design

Gear flow meters (ZHA) are positive displacement meters. Two precise gears rotate freely inside the measuring chamber.

Sealed cavities are created between the gears and the housing. The measured media causes the rotation of the gears. The flowing medium is distributed evenly in the measuring chamber and causes the rotation of the gears. The gear wheels rotate freely and undamped in the media flow. Their rotational frequency is proportional to the flow rate and is measured by non-intrusive sensors (pickups) through the housing wall.

The sensor system can be variably adjusted to meet the requirements of the application. This allows, for example, providing even very high resolutions or also a signal for determining the direction of flow.

Pulses per unit of volume are available for analysis. The calibration factor (K-factor) of the flow meter describes the exact pulse rate per unit of volume. In order to determine the individual calibration factor of a flow meter, we calibrate each of our meters in house prior to delivery. The operating viscosity specified by the customer is taken into account for calibration. A corresponding calibration certificate is included with every flow meter we supply.

These meters are suitable for accurate measurement of different liquids with viscosities of approximately 1 to 25,000 mm²/s.

Thanks to a high output frequency, excellent resolution and short response times, our gear flow meters are outstanding for measuring pulsing flows, for consumption measurement and for dosing of liquids.

Applications

- Hydraulic applications
- Cylinder monitoring
- Filling systems
- Fuel measurement
- Coolant circuit monitoring
- Dosing systems
- Lubrication monitoring
- Additive dosing

Features

- High measuring accuracy up to $\pm 0.1\%$ ¹⁾
- Exceptional repeatability of $\pm 0.05\%$
- Measuring range up to 1:150
- Short response times
- Pressure-resistant up to 420 bar [6,000 psi]
- Medium temperature up to 150 °C [302 °F]
- Robust construction and long lifetime

¹⁾ Under laboratory conditions; incl. linearization; viscosity ≥ 30 mm²/s.

Gear Flow Meters – ZHA KL Series

Technical Data – Sizes

ZHA Type ²⁾	Measuring Range (l/min)			K-Factor ³⁾ (pulses/l)	max. Pressure (bar/psi)	Frequency ³⁾ (Hz)			Weight (kg)
ZHA 01/2	0.02	up to	3.0	14,000	420 [6,000]	4.6	up to	700	0.8
ZHA 02	0.1	up to	7.0	4,200	420 [6,000]	7	up to	490	1.2
ZHA 03	0.5	up to	25.0	1,740	420 [6,000]	14	up to	730	1.3
ZHA 04	0.5	up to	75.0	475	345 [5,000]	4	up to	590	4.1

Technical Data – General

Measuring Accuracy	Up to ± 0.1 % ⁴⁾
Repeatability	± 0.05 % (under the same conditions)
Linearity	± 0.5 % of actual flow (viscosity ≥ 30 mm ² /s)
Materials	Housing: as per DIN 3.4365 (EN AW 7075) Gears: as per DIN 1.4122 Bearing: Stainless steel ball bearing Seals: FKM, PTFE
Medium Temperature	-40 °C up to +150 °C [-40 °F up to +302 °F] (others on request)
Dimensions	See dimensional drawing (page 5 to 6)



²⁾ Exact type designation see ordering code (page 7).

³⁾ Average values for single sensors, dual pickups and higher resolution available.

⁴⁾ Under laboratory conditions; incl. linearization; viscosity ≥ 30 mm²/s.

Dimensional Drawing – ZHA 01/2 to 04

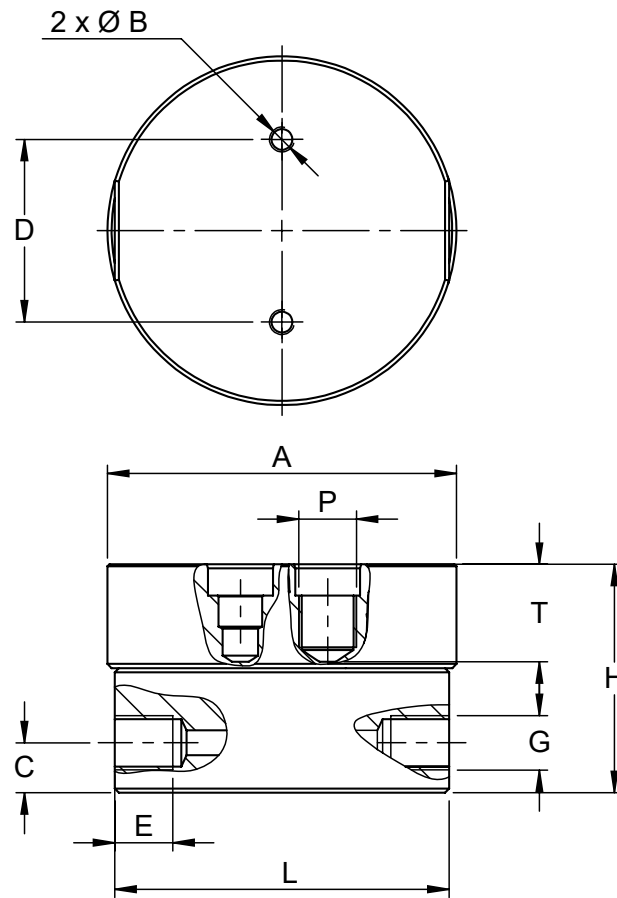

ZHA Type	Ø A	B	C	D	E	G ⁵⁾	H	L	P ⁶⁾	T ⁶⁾
ZHA 01/2	76.0 mm [2.99 in]	M6 ∇ 10	12.0 mm [0.47 in]	44.0 mm [1.73 in]	14.0 mm [0.55 in]	G ¼", ¼" NPT	55.0 mm [2.17 in]	72.0 mm [2.83 in]	R	23.5 mm [0.93 in]
ZHA 02	84.0 mm [3.31 in]	M6 ∇ 10	12.0 mm [0.47 in]	44.0 mm [1.73 in]	14.0 mm [0.55 in]	G ¼", ¼" NPT	55.0 mm [2.17 in]	80.5 mm [3.17 in]	R	23.5 mm [0.93 in]
ZHA 03	84.0 mm [3.31 in]	M6 ∇ 10	15.0 mm [0.51 in]	44.0 mm [1.73 in]	16.0 mm [0.63 in]	G ½"	67.0 mm [2.64 in]	78.0 mm [3.077 in]	R	23.5 mm [0.93 in]
						½" NPT		80.5 mm [3.17 in]		
ZHA 04	125.0 mm [4.92 in]	M8 ∇ 15	19.0 mm [0.75 in]	60.0 mm [2.36 in]	17.0 mm [0.67 in]	G ¾", ¾" NPT	107.0 mm [4.21 in]	119.0 mm [4.69 in]	R	30.5 mm [1.20 in]

⁵⁾ Others on request.

⁶⁾ Only applies for single pickup holes of type „R“.

Attention: the total installation height is the result of the height (H) and the height of the electronics (dimensions in separate datasheet).

Gear Flow Meters – ZHA KL Series

Ordering Code

ZHA - XX - XX - X - X

Measuring Range

0.02 - 3.0 l/min	01/2
0.1 - 7.0 l/min	02
0.5 - 25.0 l/min	03
0.5 - 75.0 l/min	04

Meter Attributes

Housing	Gears	Bearing	Thread	
3.4365 [EN AW-7075]	1.4122	ball bearing	BSPP	KL
3.4365 [EN AW-7075]	1.4122	ball bearing	NPT	KN

Sensor Ports

M14x1,5 & Plug-in (frequency doubling, direction detection)	R
---	---

Sealing Options

FKM (Viton®)	V
PTFE (Teflon®)	T



Pressure Drop Curves

ZHA 01/2

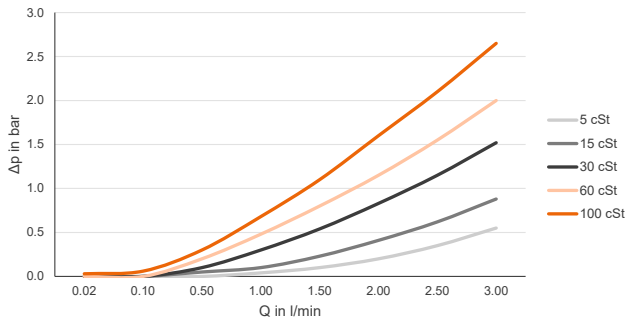

ZHA 02

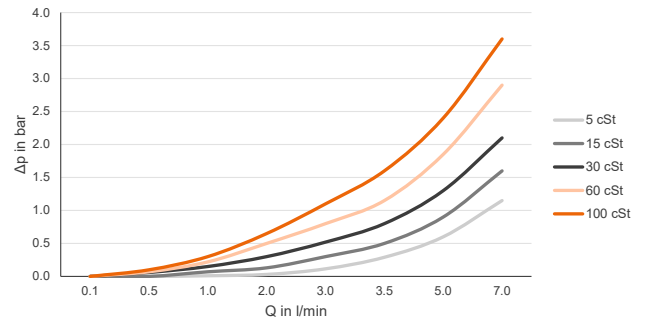

ZHA 03

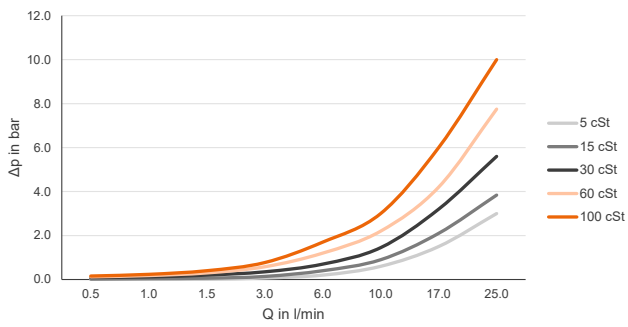

ZHA 04

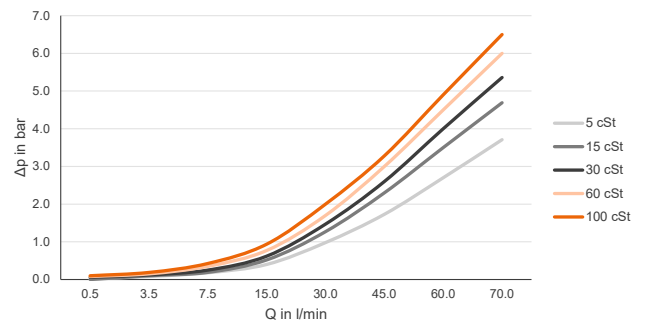

Calibration

In-house calibration is performed on volumetric calibration rigs or in our accredited calibration laboratory, depending on the needs of the client.

The calibrations are performed with different hydrocarbons. This ensures the optimum simulation of changing operating conditions in density and viscosity even when temperatures change. This way the primary viscosity for the use of the flow meter can be specifically taken into account when viscosity fluctuations occur in a customised application.

The calibration result is the specified calibration factor (K-factor) in pulses per litre. This K-factor accordingly applies only at a certain flow velocity or a certain flow rate. The calibration factor varies only very slightly at different volume flow rates. The individual measuring points provide the calibration curve of the flow meter from which the average K-factor is determined. The average calibration factor applies to the entire measuring range.

The linearity specification (percent deviation) refers to the average K-factor. To further increase the measurement accuracy in onsite use, the specific K-factors can be used to calculate the flow rate. For this, KEM also supplies optional special electronics.

For special requirements on the traceability of the results, it is possible to perform an accredited calibration on customer request. The KEM accredited calibration lab uses a high-precision load cell system. With an accuracy of 0.05 % for the mass and 0.1 % for the volume of flowing liquids, we occupy a leading position worldwide. The laboratory is accredited with engineers, processes and measuring equipment according to the international standard DIN EN ISO/IEC 17025:2018.

The KEM accredited calibration certificate not only verifies the accuracy of a flow meter, but also guarantees its traceability to national standards ensuring all requirements according to international quality standards are met.

Calculation of volume flow

The flow is directly dependent on the measured frequency and the associated calibration factor:

$$Q = \frac{f \cdot 60}{K} \text{ l/min}$$

Q = Volume Flow
f = Measuring frequency
K = Specific K-Factor

Calibration protocol

Example: ZHA 02 (0.1 to 7 l/min)

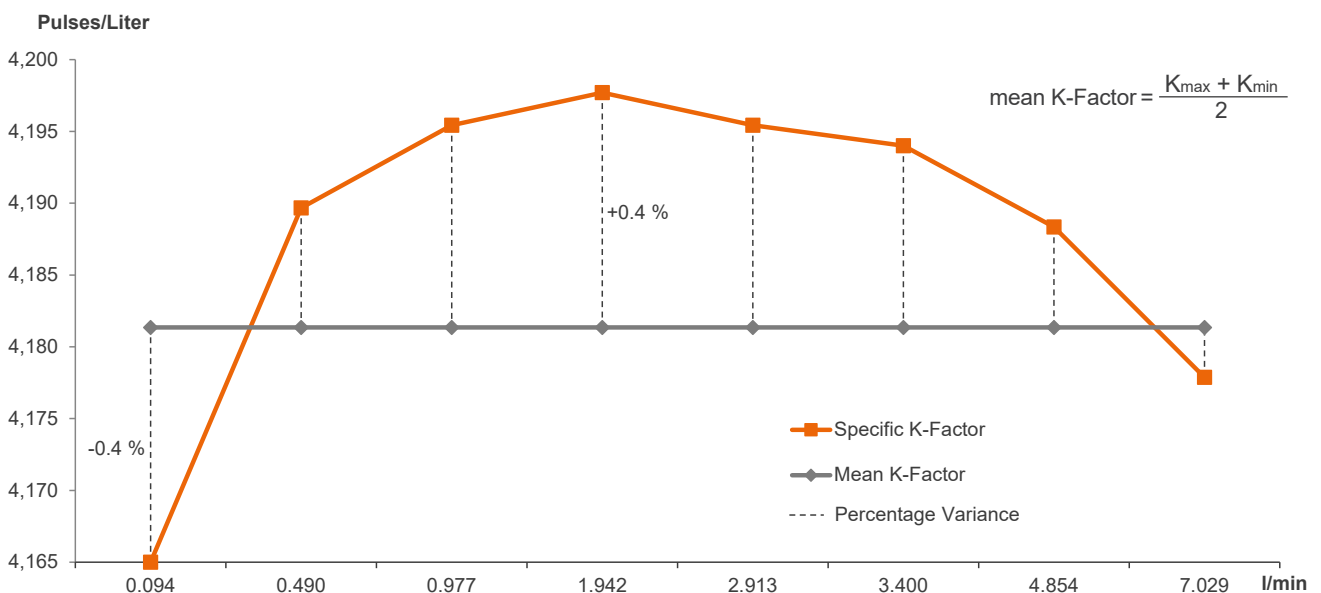



KEM Flow Measurement GmbH



+49 9941 9423-0



Wetzeller Straße 22
93444 Bad Kötzing
Germany



info@kemflow.com



www.kemflow.com